

STEP 1

Drill the center front hole 3/8" up from bottom of chin piece using a 7/32" drill bit.

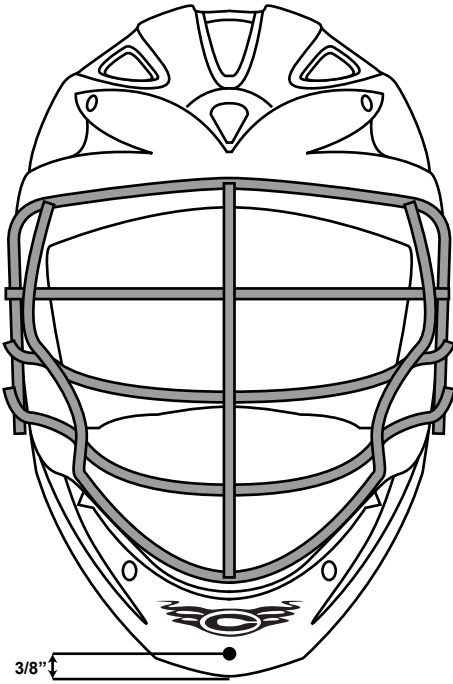

STEP 2

Drilling each side hole location depends on your helmet, choose your helmet below.

You will need to measure from the center of the side hook-up screw to the specified location.

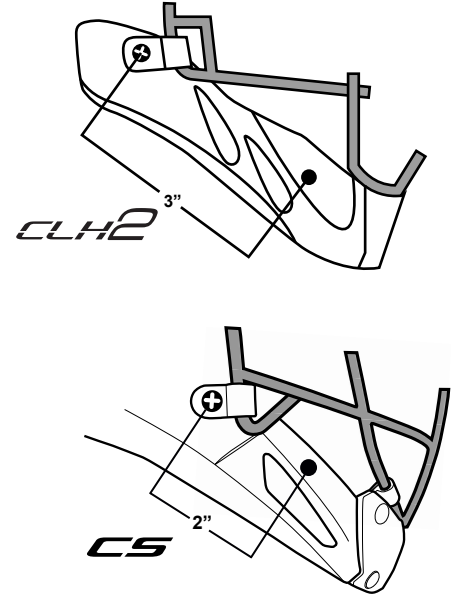
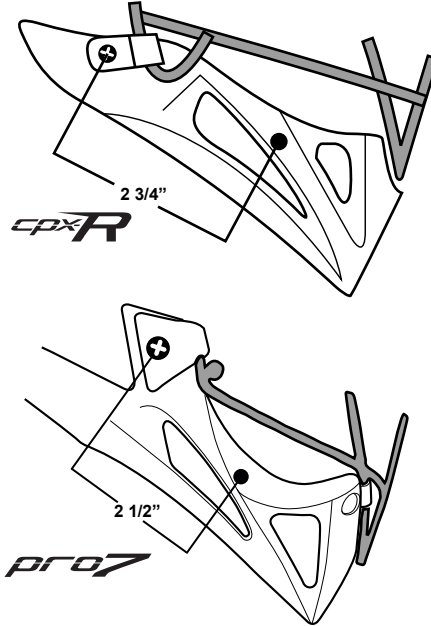

CPV-R | CPV For these models, hole locations are marked by indentations on the inside of the chin piece.

Parts

- 1 TPC2 throat piece,
- 1 short, 2 long t-nuts,
- 2 silver screws, 2 silver bushings,
- 1 black screw, 2 black bushings.

Tools Needed

- Drill, 7/32" drill bit, ruler,
- Phillips head screwdriver, marker.

STEP 3

Center Front : Follow the illustration to hook up webbing to your chin piece.

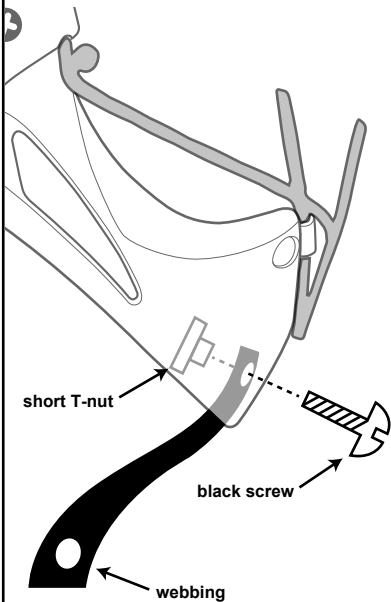

STEP 4

Side: Follow illustration to hook up the left side. Then mirror for the right. Screw head must be flush to silver spacer. **Do not over tighten.**

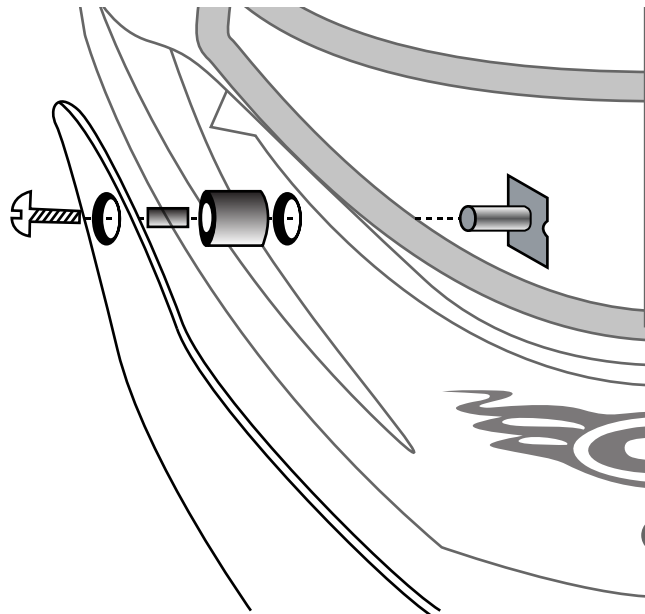

All pieces must be installed for the TPC2 to work properly. Make sure the TPC2 moves freely up and down. Check that all 3 screws are firmly tightened.

DO NOT USE IF THE TPC2 DOES NOT FREELY MOVE OR IS CRACKED

Please call us @ 1.800.537.1702 if you need assistance.

WARNING

No equipment can prevent all injuries. Lacrosse is a body contact sport. The ball moves at high speed. People get hurt and killed playing the game of lacrosse. This TPC2 throat piece cannot prevent all injuries to the neck, face, eyes, teeth, brain, skull and body. Some steps to reduce your risk of injury are to: follow the rules of the game, be smart, and carefully inspect all of your equipment prior to each time you go onto the field. Do not use equipment that is bent, broken, or defective.